

SUNQUEST 26RS HOOD

LINE INPUT → P1 P2 → BENCH

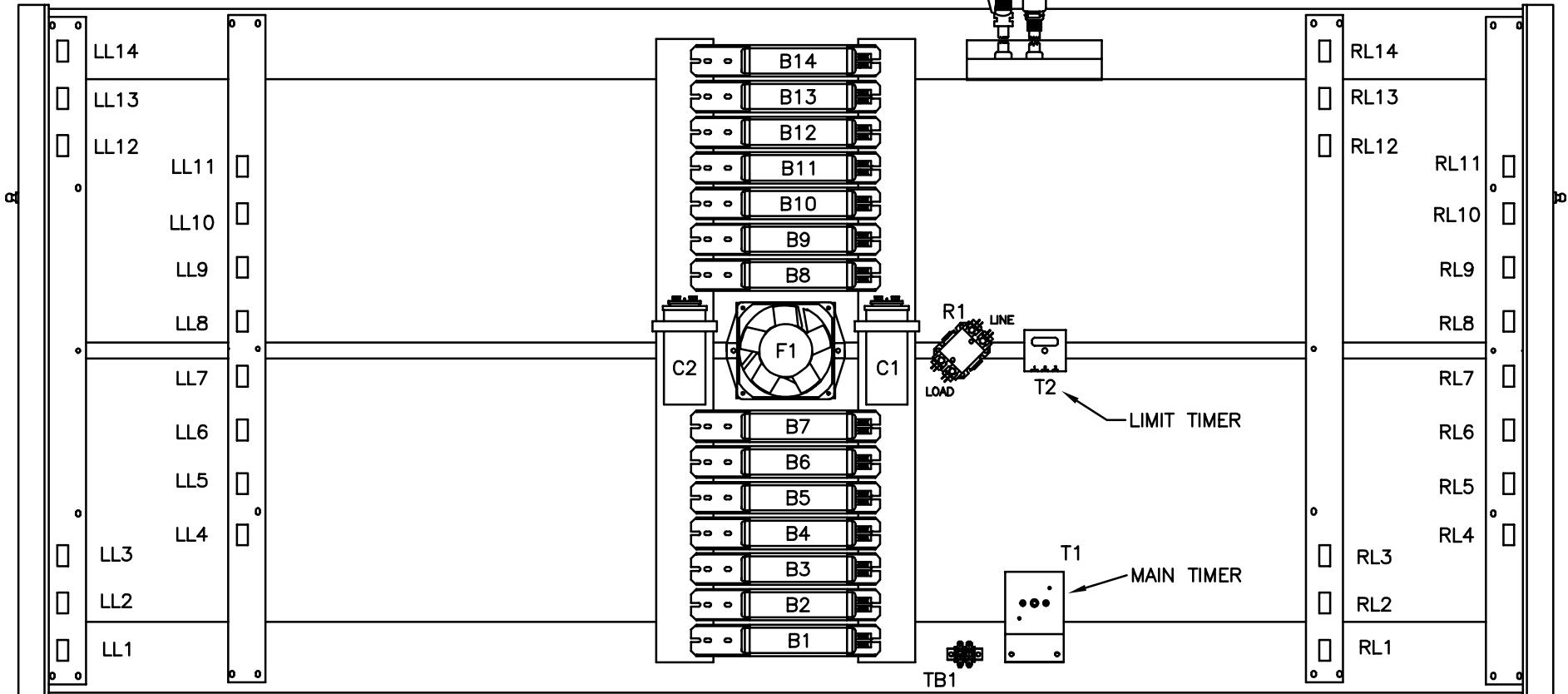

LL = LEFT LAMPHOLDER
 B = BALLAST
 F = FAN
 R = RELAY (CONTACTOR)
 TB = TERMINAL BLOCK

RL = RIGHT LAMPHOLDER
 C = CAPACITOR
 P = POWER
 T = TIMER

FRONT OF BED



6220 CHURCHMAN BYPASS
 INDIANAPOLIS, IN 46203

21239 REV. B

NOTE:

1. WIRE COLORS MAY NOT BE EXACTLY AS SHOWN

SUNQUEST 26RS HOOD

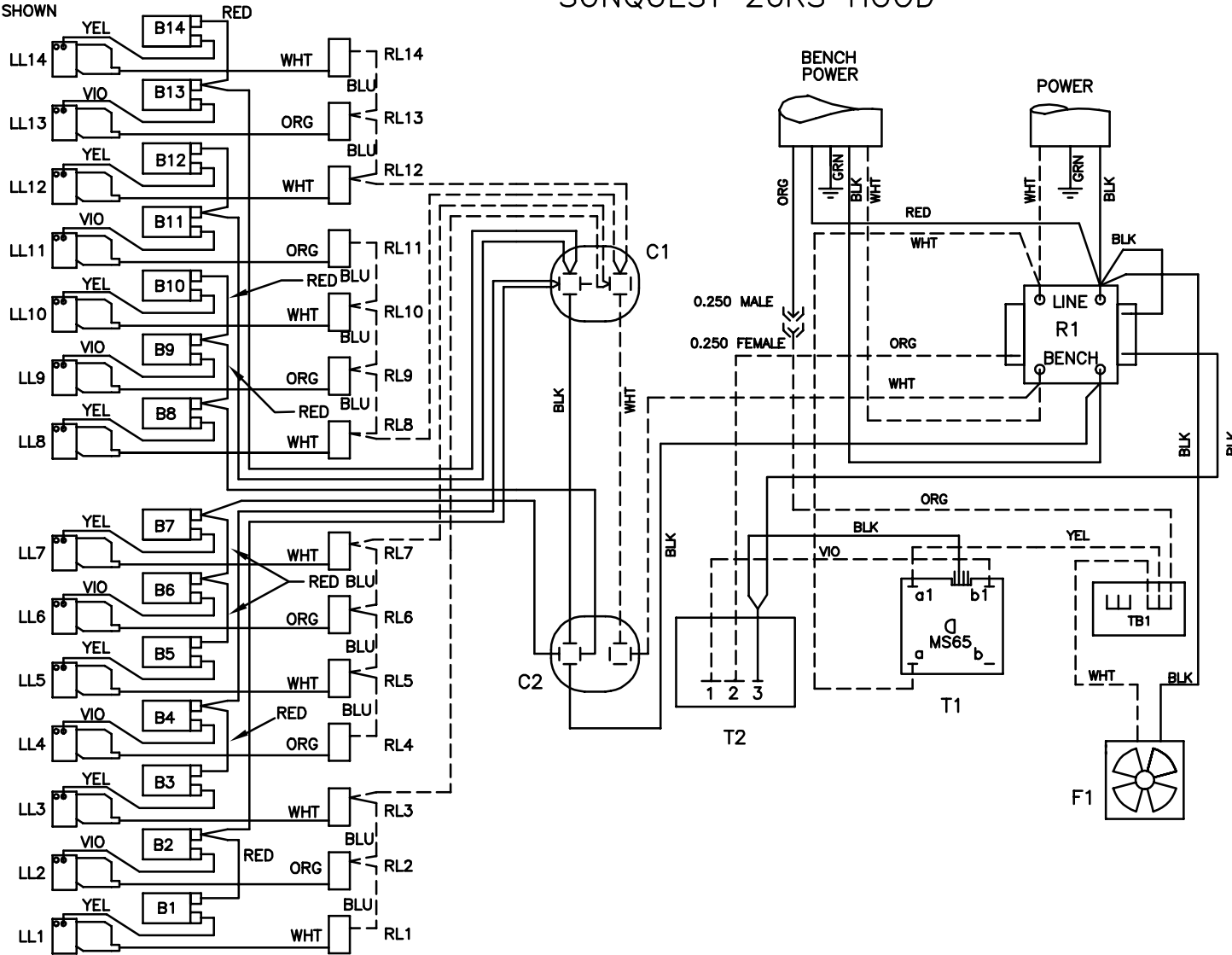

LL = LEFT LAMPHOLDER
 B = BALLAST
 R = RELAY (CONTACTOR)

RL = RIGHT LAMPHOLDER
 C = CAPACITOR
 T = TIMER

TB = TERMINAL BLOCK

WARNING: ALTERING THE DESIGN, TIMER SYSTEM, OR WIRING FROM THAT SHOWN HEREIN, WILL VOID THE WARRANTY, AND MAY RESULT IN A VIOLATION OF FEDERAL LAW.

SUNQUEST PRO 26RS BENCH

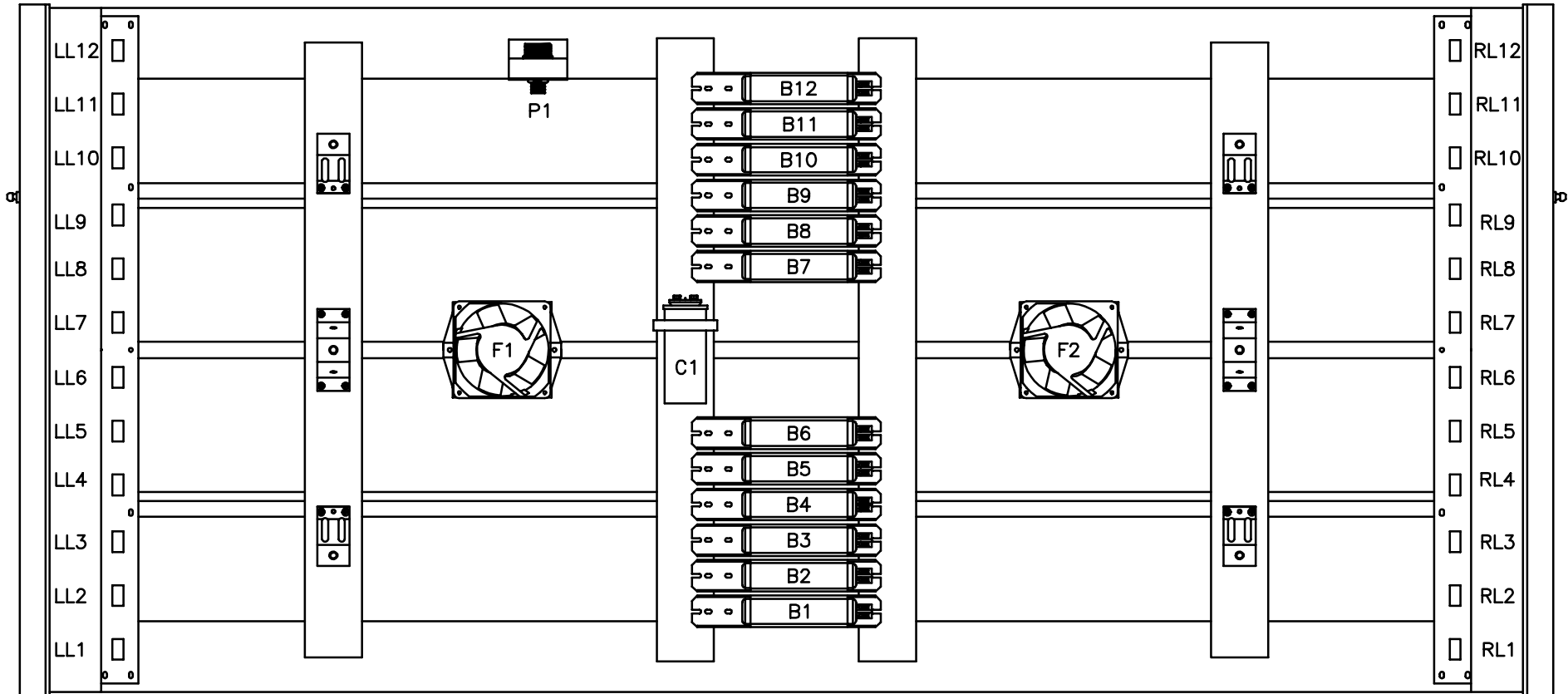

LL = LEFT LAMPHOLDER
 B = BALLAST
 F = FAN

RL = RIGHT LAMPHOLDER
 C = CAPACITOR
 P = POWER JACK

FRONT OF BED



6220 CHURCHMAN BYPASS
 INDIANAPOLIS, IN 46203

21574 REV. B

SUNQUEST PRO 26RS BENCH

NOTE:
1. WIRE COLORS MAY NOT BE EXACTLY AS SHOWN

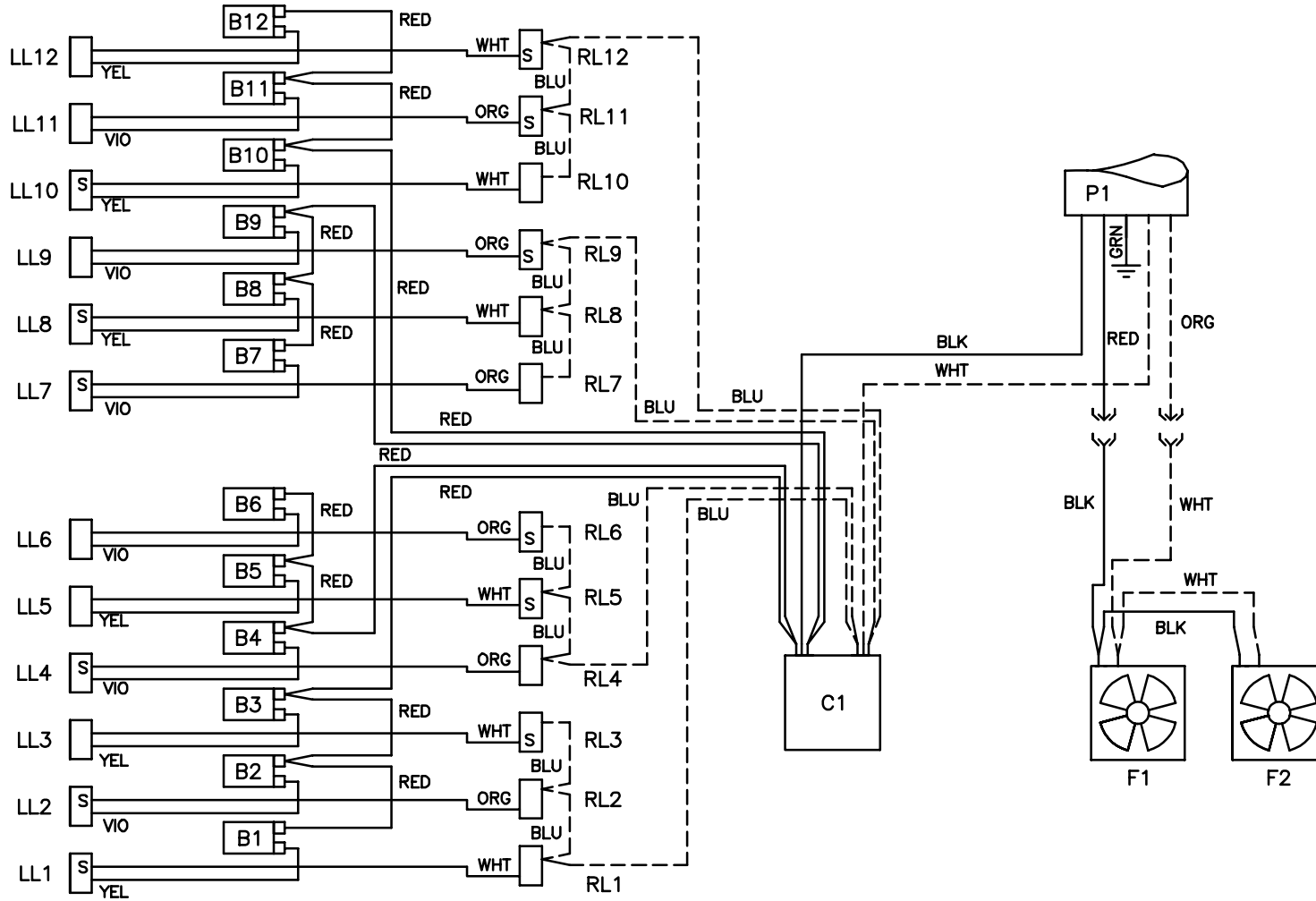

LL = LEFT LAMPHOLDER
B = BALLAST
F = FAN
S = STARTER

RL = RIGHT LAMPHOLDER
C = CAPACITOR
P = POWER JACK

WARNING: ALTERING THE DESIGN, TIMER SYSTEM, OR WIRING FROM THAT SHOWN HEREIN, WILL VOID THE WARRANTY, AND MAY RESULT IN A VIOLATION OF FEDERAL LAW.