

NOTE:
1. WIRE COLORS MAY NOT BE EXACTLY AS SHOWN

220 VAC IN TO BENCH TO REMOTE

SUNSTAR 32 TURBO HOOD
WIRING DIAGRAM

22351 REV. C

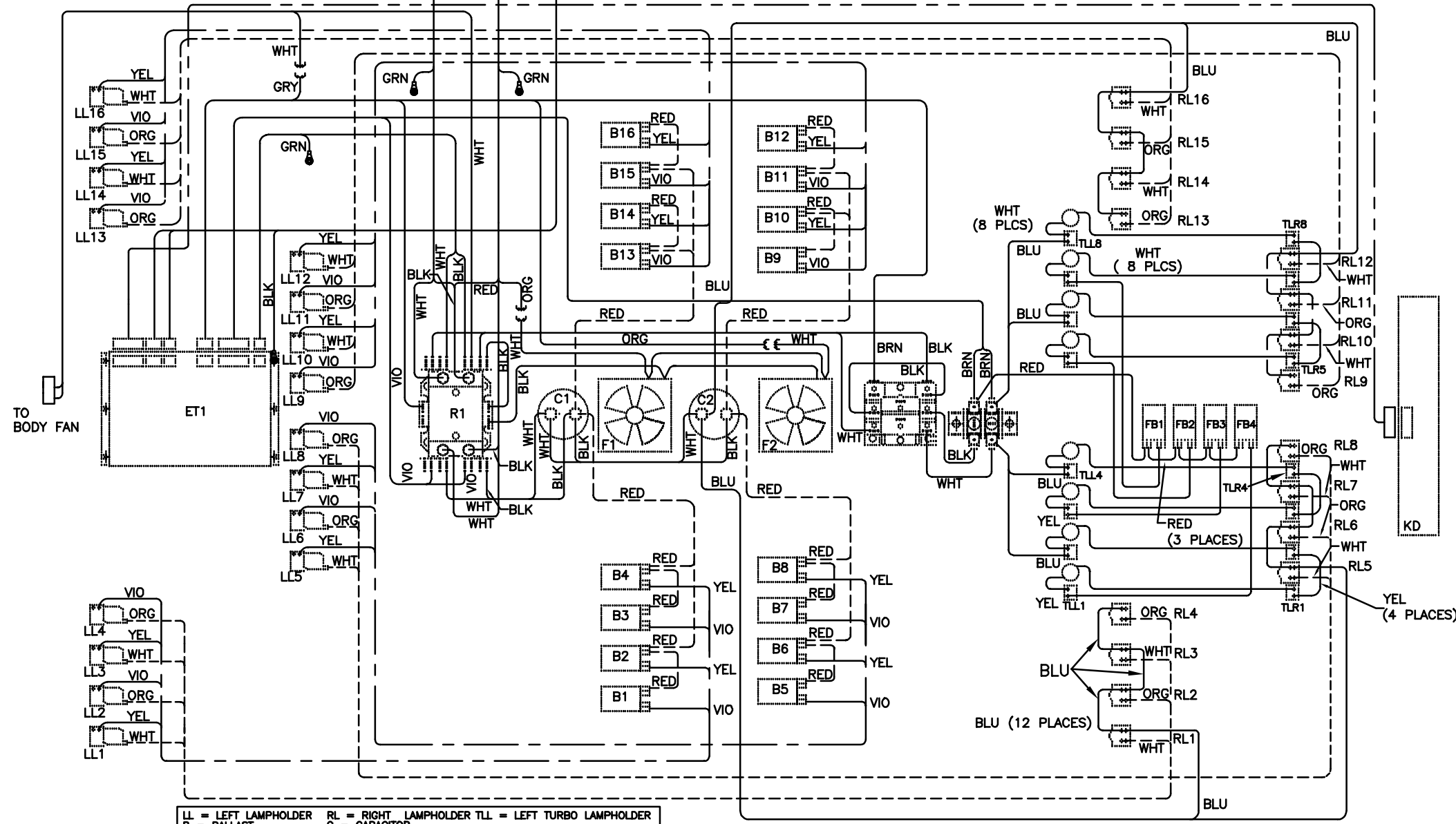

LL = LEFT LAMPHOLDER	RL = RIGHT LAMPHOLDER	TLL = LEFT TURBO LAMPHOLDER
B = BALLAST	C = CAPACITOR	TLR = RIGHT TURBO LAMPHOLDER
F = FAN	P = POWER	
R = RELAY (CONTACTOR)	ET = ELECTRONIC TIMER	FB = FACE TANNER BALLAST
KD = KEYPAD/DISPLAY	G = CHASSIS GROUND	

NOTE:
1. WIRE COLORS MAY NOT BE EXACTLY AS SHOWN

SUNSTAR 32 BENCH WIRING DIAGRAM

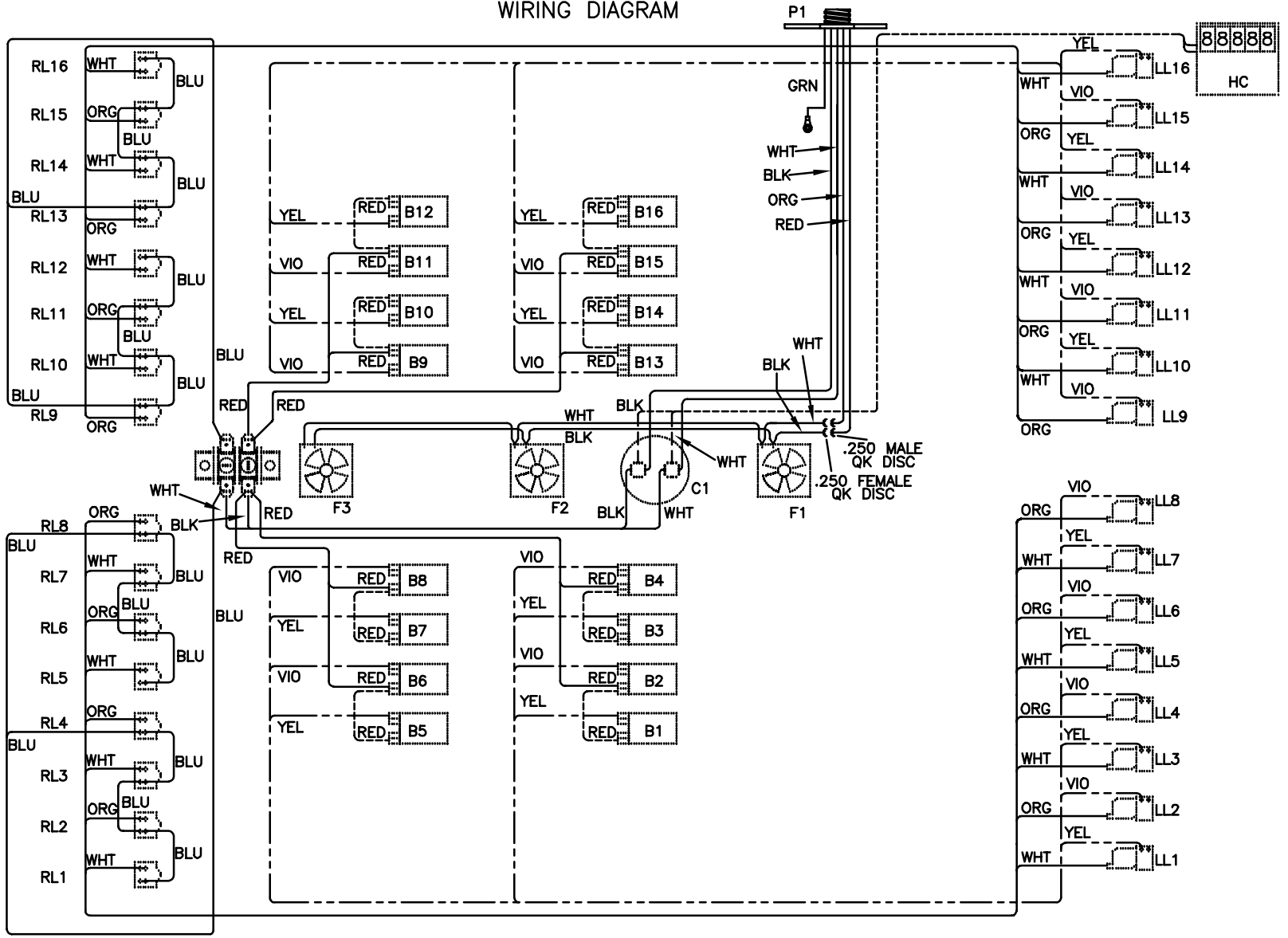

LL = LEFT LAMPHOLDER
B = BALLAST
F = FAN
HC = HOUR COUNTER
RL = RIGHT LAMPHOLDER
C = CAPACITOR
P = POWER

FRONT OF BED
(BOTTOM SIDE UP)

WARNING: ALTERING THE DESIGN, TIMER SYSTEM, OR WIRING FROM THAT SHOWN HEREIN, WILL VOID THE WARRANTY, AND MAY RESULT IN A VIOLATION OF FEDERAL LAW.